

Tutorial Set 1: Revision of Basic AC Circuits

Q.1 Write down the peak and rms values, frequency, phase, complex and phasor representations of the following ac quantities.

(a) $5\sqrt{2} \sin(\omega t)$

(b) $5\sqrt{2} \cos(\omega t)$

(c) $10\sqrt{2} \sin(20t + 30^\circ)$

(d) $120\sqrt{2} \cos(314t - 45^\circ)$

(e) $-50 \sin\left(4t - \frac{\pi}{3}\right)$

(f) $0.25 \cos(2t + 100^\circ)$

Q.2 Taking the frequency to be 50 Hz, write down the sinusoidal voltages and currents corresponding to the following phasors.

(a) $\frac{100}{\sqrt{2}} e^{j30^\circ} \text{ V}$

(b) $115 e^{j\pi/3} \text{ V}$

(c) $-0.12 e^{-j\pi/4} \text{ A}$

(d) $-0.69 \angle 60^\circ \text{ A}$

Q.3 In the following ac circuit, $v_R(t) = 12\sqrt{2} \cos(2t) \text{ V}$.

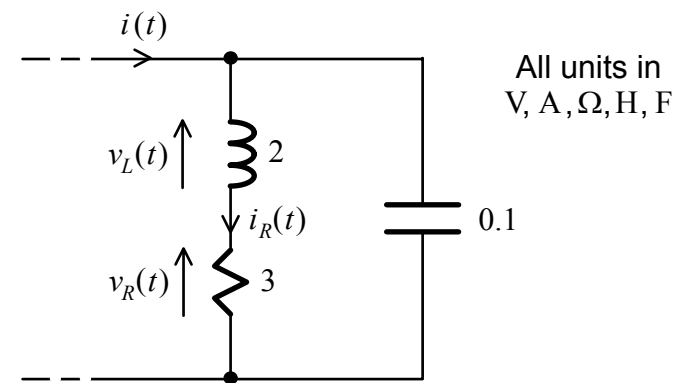

Determine $i_R(t)$, $v_L(t)$ and $i(t)$ by using phasor analysis.

Q.4 The following diagram shows the Thevenin's equivalent circuit of an ac system when connected to a load with impedance $Z = R + jX$.

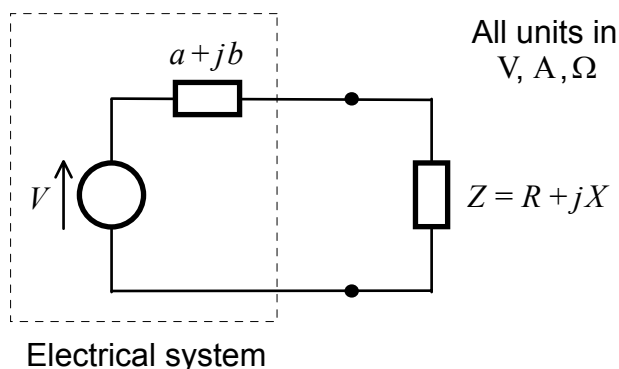

Show that R and X should be given by

$$Z = R + jX = (a + jb)^* = a - jb$$

in order for the load to absorb the maximum power. Determine this maximum power.

Q.5 Using Norton's equivalent circuit, determine the maximum power that can be absorbed by the load with impedance Z in the following ac system.

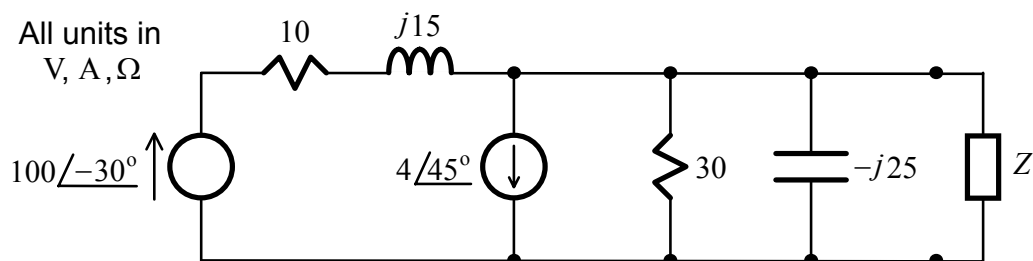

Tutorial Set 2: Transients I

- Q.1 The current $i(t)$ in the following figure flows through a 5 H inductor and an initially uncharged $5 \mu\text{F}$ capacitor.

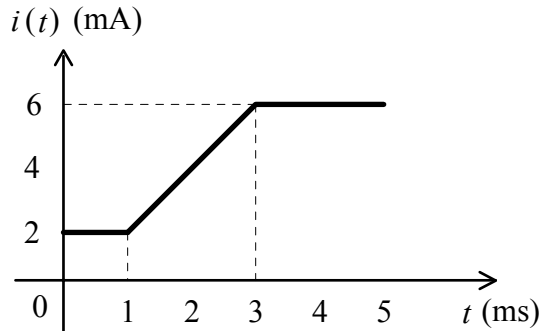

Plot the voltages across the inductor and capacitor as functions of time t .

- Q.2 In the following circuit, the two switches have been in the positions shown for $t < 0$ and are thrown to the other positions for $t \geq 0$.

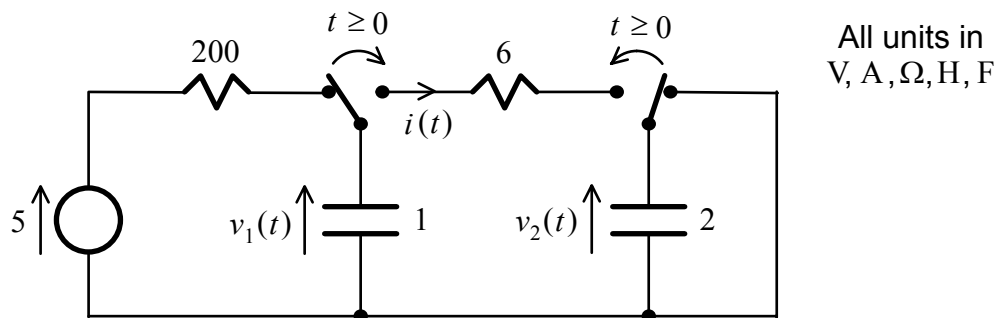

- Assuming that the switches have been in their original positions for a long time so that the voltages and currents in the circuit have settled down to constant values, determine the values of $v_1(t)$, $v_2(t)$ and $i(t)$ for $t < 0$.
- Determine $v_1(t)$, $v_2(t)$ and $i(t)$ just after the switches were thrown to the other positions at $t = 0$.
- Derive and solve the governing differential equation for $i(t)$ for $t \geq 0$. Hence, obtain expressions for $v_1(t)$ and $v_2(t)$ for $t \geq 0$.
- Sketch $v_1(t)$, $v_2(t)$ and $i(t)$ as functions of t .

Q.3 In the following circuit, the switch has been closed for a long time. At time $t = 0$, the switch is opened.

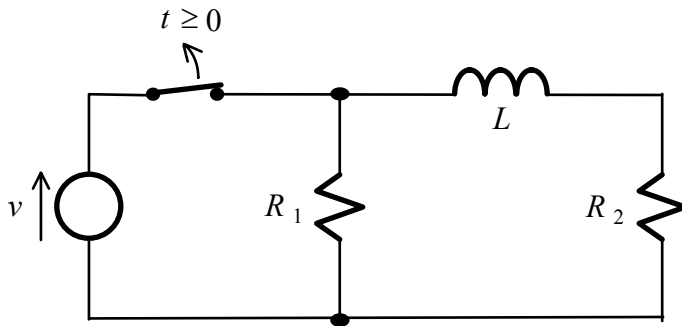

- Determine the voltages and currents in the circuit for $t < 0$. What is the energy stored in the inductor?
- Determine the current in the inductor $i(t)$ just after the switch is opened at $t = 0$.
- Derive an expression for $i(t)$ for $t \geq 0$.
- By integrating $(R_1 + R_2)i^2(t)$, determine the energy consumed by the resistors after the switch is opened. Derive the same result by using conservation of energy.

Q.4 In the following diagram, the inductor is carrying a current of 32 A when the switch on the left is turned from the position shown to the other position at time $t = 0$. At the end of 3 s, the other switch is closed.

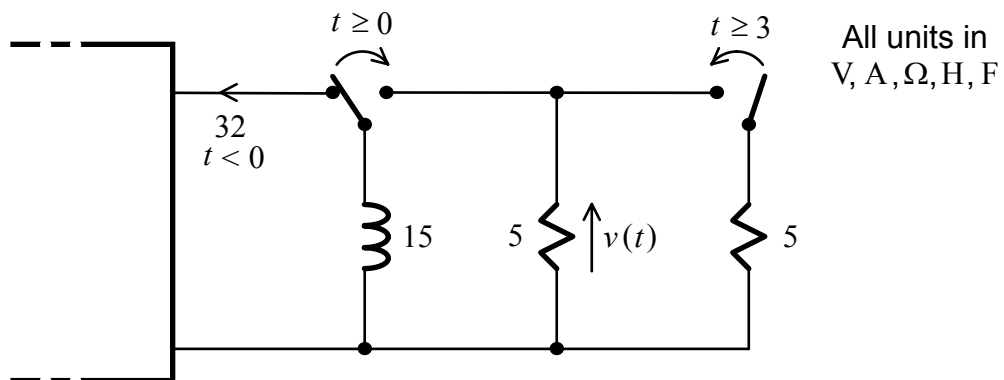

All units in V, A, Ω , H, F

Derive an expression for $v(t)$ and sketch it.

Tutorial Set 3: Transients II

- Q.1 In the following circuit, the switch has been opened for a long time. At time $t = 0$, the switch is closed.

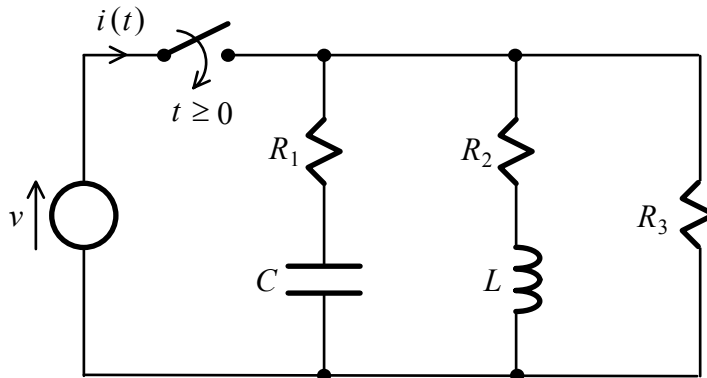

Derive an expression for $i(t)$ as a function of time. For what values of R_1 , R_2 and R_3 will this current be independent of time?

- Q.2 In the following circuit, the switch is opened at $t = 0$ after steady state conditions have prevailed.

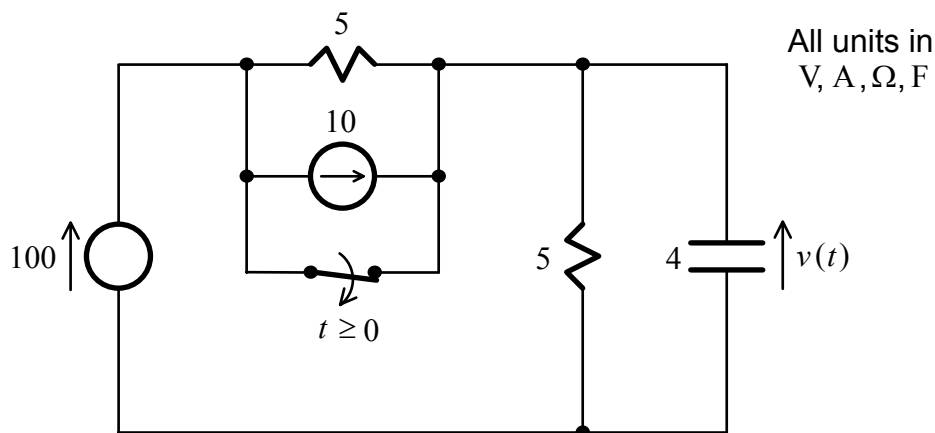

Derive an expression for $v(t)$ for $t \geq 0$.

Q.3 In the following circuit, the capacitor is initially charged to 10V before the switch is closed.

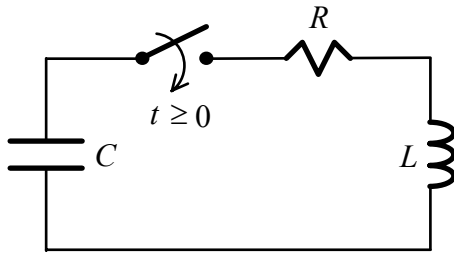

- Determine the voltages and current in the circuit before the switch is closed.
- Determine the voltages and current just after the switch is closed at $t = 0$.
- Derive the governing differential equation for the current for $t \geq 0$. Express all the constants involved in terms of the resonant frequency and Q factor of the circuit. What are the initial conditions that have to be satisfied?
- Determine and sketch the current for $t \geq 0$ under the overdamped situation of $Q < \frac{1}{2}$.
- Determine and sketch the current for $t \geq 0$ under the underdamped situation of $Q > \frac{1}{2}$.
- Determine and sketch the current for $t \geq 0$ under the undamped situation when $R = 0$.

Q.4 In the following circuit, the capacitor is initially uncharged and there is no current through the inductor when the switch is closed at time $t = 0$.

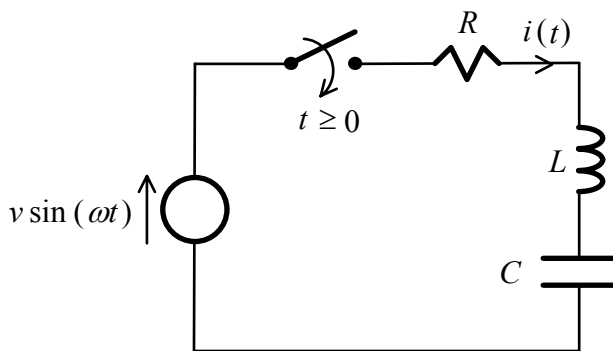

Derive the governing differential equation and initial conditions for finding the circuit current $i(t)$ for $t \geq 0$. Determine the steady state current.

Tutorial Set 4: State Variable Analysis

Q.1 Consider the circuit given below.

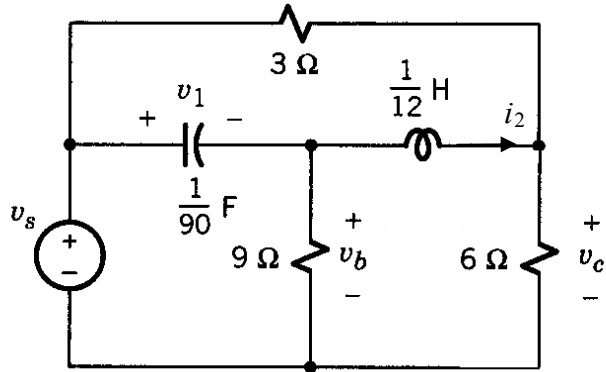

- Derive the state and output equations for the circuit by taking v_1 and i_2 as the state variables, v_b and v_c as the outputs, and v_s as the input.
- Assuming that $v_1(0) = 1$, $i_2(0) = 2$ and $v_s(t) = 1$, express the complete response of the circuit in terms of the inverse Laplace transform.
- Compute the transfer function of the circuit and the poles of the system. Is the system stable?

Q.2 Consider the circuit given below.

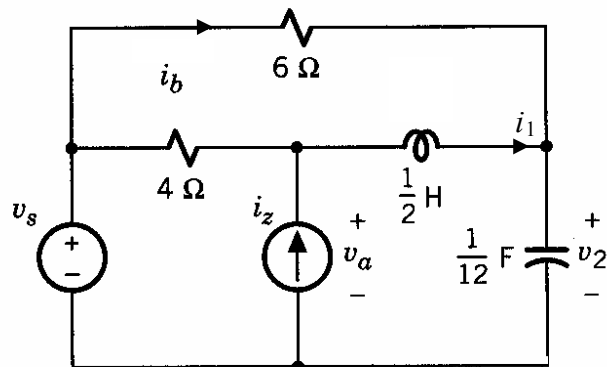

- Derive the state and output equations for the circuit by taking i_1 and v_2 as the state variables, i_b and v_a as the outputs, and i_z and v_s as the inputs.
- Compute the transfer function of the circuit and the poles of the system. Is the system stable?

Q.3 Consider the circuit given below.

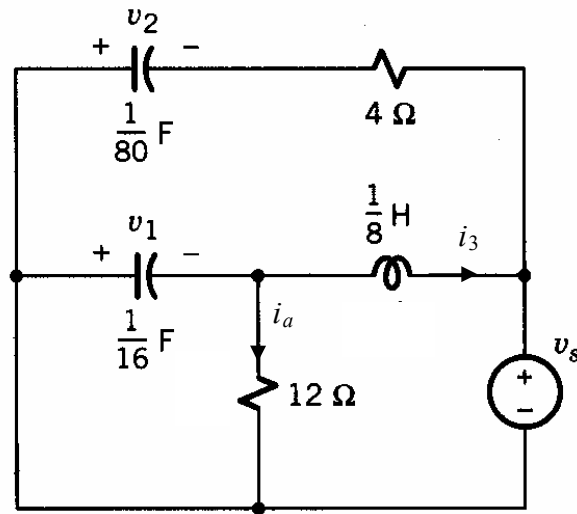

- Derive the state and output equations for the circuit by taking v_1 , v_2 and i_3 as the state variables, i_a as the output, and v_s as the input.
- With the help of MATLAB, compute the transfer function of the circuit and the poles and zeros of the system. Is the system stable?
- Assuming that $v_1(0) = 1$, $v_2(0) = 5$, $i_3(0) = 2$ and $v_s(t) = 3 \sin 2t$, with the help of MATLAB and SIMULINK, simulate the complete response of the circuit.

Note: For Parts (b) and (c) above, tutors can just explain in the tutorial sessions on how to use related MATLAB and SIMULINK functions. Students should try to find out the solutions themselves.